



KITCHEN APPLIANCES

COOK MORE, LOVE MORE

With FOTILE, cooking is a lot easier and happier,
the more you cook the more you love.

RANGE HOOD | HOB
COMBI OVEN | OVEN | MICROWAVE OVEN | STEAM OVEN
DISHWASHER | WATER PURIFIER

FOTILE

Brand Story

Since its inception in 1996, FOTILE has carved a niche in the industry of being the No. 1 high end kitchen appliances brand in China, specializes in developing built-in kitchen appliances like range hoods, hobs, cooking range, combi oven, ovens, microwave ovens, dishwasher and water purifier.

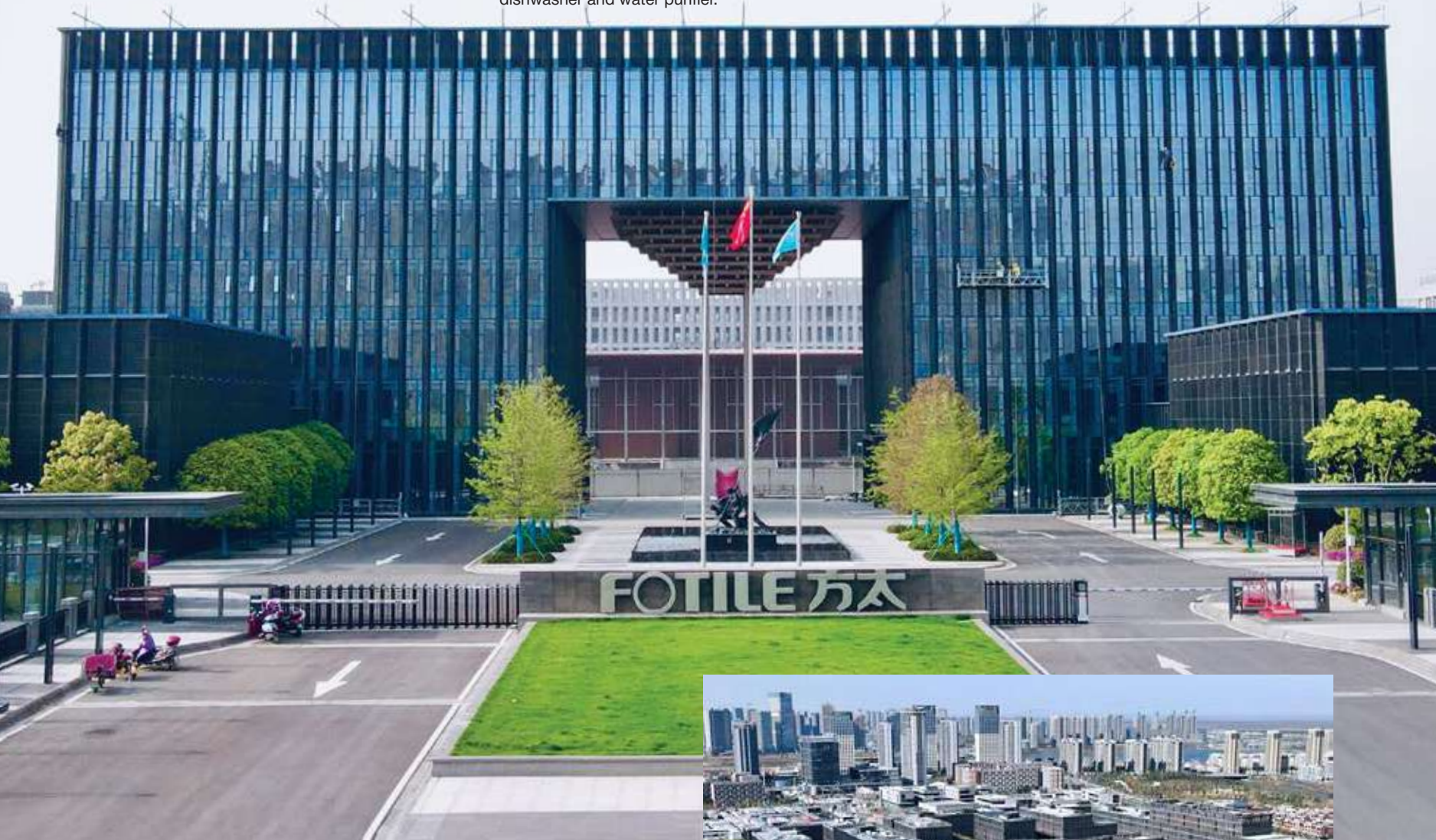

We have the largest R&D center in the world covering an area of **8000sqm**. With technology, innovative design and performance as the key factors in Fotile manufacturing, we have achieved **16,000+** patents in product and **4100+** in invention, bringing innovative and good quality product to over 17 millions of families around the world. FOTILE commitments to excellence not only bringing satisfaction to our customers, we have win a numerous international accolades namely RedDots design awards, IF Product Design Award that uplifting the industry standard of designs and product innovations.

At FOTILE, our business is built on the foundation of product innovation and creating kitchen appliances that are functional, stylish and family oriented. That is why FOTILE is constantly inventing, designing and creating extraordinary products while maintaining its reputation as a leading kitchen expert that puts families at the first place.

Marking a remarkable milestone, FOTILE has launched its first largest kitchen appliances gallery named the “Fotile Style”, located at TaoJiang road, Shanghai, in year 2012. This gallery showcases the brand’s most prestigious kitchen appliances. A ‘futuristic corner’ is introduced in this gallery, allows visitors to take a glimpse into some of FOTILE’s most innovative technology.

With over 20 years of experience in servicing Malaysian customers, FOTILE Marketing Sdn. Bhd as the sole distributor of FOTILE kitchen appliances in Malaysia, has the expertise to offer functional and stylish kitchen appliances that suited to Asian cooking.

Today, FOTILE Malaysia enjoys its position as a reputable premium kitchen appliances brand in Malaysia with a strong following of happy and satisfied customers. We strive to innovate our product and service, providing a full spectrum of cooking solutions that caters to every Malaysian kitchen need.

· Dusseldorf, Germany; Osaka, Japan; Ningbo, China; three global centers.

· Revise international standards* for extractor hoods

* IEC 60335-2-31: Household and Similar Electrical Appliances-Safety-Part 2-31: Particular Requirements for Range Hoods and Other Cooking Fume Extractors

* The patents are mainly in China.

INTERNATIONAL CERTIFICATIONS AND STANDARDS



DESIGN AWARDS



FOTILE X

Free Space, Free Breath

92.9%

Oil Filtration Rate

98%

Odor Reduction Rate

NEW

BLDC
INVERTER MOTOR



CLOSER EXTRACTION

CLOSER AT THE SOURCE

Only **325mm** from the stove - almost half the distance of a traditional range hood to capture cooking smoke straight at the source.

WIDE SUCTION PLATE

Its **900mm-wide** suction plate intercepts cooking smoke and extracts it before it spreads.

STRONGER EXTRACTION

BRUSHLESS DIRECT-CURRENT INVERTER (BLDC)

The BLDC motor uses Microchip Technology along with field-oriented (FOC) algorithm boosts maximum static pressure up to **1480Pa** with an unrestrained airflow of **2800m³/h** to remove cooking smoke while keeping noise level as low as **39dB**.

AUTO TURBO SYSTEM

Increase extraction power automatically when resistance is detected.

FASTER COOKING SMOKE HIGHWAY

REAR EXTRACTION DESIGN

180° motor placement, actively reducing the distance of cooking smoke and extracting it in a straight path.

PATENTED NAUTILUS AIR PASSAGEWAY

Reduces wind resistance and noise. With the 3-point Extraction System, cooking smoke is collected, extracted and removed in a single uninterrupted path.

Patent No. 01132056.7.

SMARTER AIR DISTRIBUTION

INTELLIGENT AIR DISTRIBUTION

With a touch of a button, the FOTILE X-Series can **focus its extraction power** to either side of the hood.



STRONGER EXTRACTION POWER

Divert extraction power up to **70%** on either side of the hood.



HIGHER AIR PRESSURE

Increase air pressure for another **50%** on either side of the hood.

SMART SYNC

Upon gas hob ignition, range hood automatically turns on to remove cooking smoke.

Needs to be paired with FOTILE's gas hob that has smart sync feature.

SMART SMOTION (SMOKE + MOTION) DETECTION

Turn the hood on and off with the wave of a hand.

EASY TO CLEAN

All-new filter-free design with glass frame, just wipe to restore it to its original lustre.

LOW NOISE LEVEL

BLDC motor with multiple noise-reduction technologies. Noise level produced is as low as 39dB.

FOTILE Z

Where Eastern Innovation Meets Western Elegance

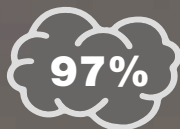

Odor Reduction Rate



STRONGER EXTRACTION

BRUSHLESS DIRECT-CURRENT INVERTER (BLDC)

The BLDC motor boosts maximum static air pressure up to **1170Pa** with an unrestrained air flow of **2450m³/h** to remove cooking smoke while keeping noise level as low as **40dB**.

AUTO TURBO SYSTEM

Increase extraction power automatically when resistance is detected.

INTELLIGENT SUCTION & EXTRACTION SYSTEM

DELAY OFF TIMER

Hood will run for 2 minutes to extract the remaining cooking smoke in your kitchen.

INTELLIGENT AIR MANAGEMENT

Ventilates harmful gases in the kitchen automatically to keep the kitchen air fresh.

Air Condition	Good	Poor	Severe
Fan Speed	Off	Medium	Strong

SPACIOUS ENTRY CAVITY

OPTIMAL COOKING SMOKE CONTROL ZONE

Only **560mm** from the stove. Fully trap cooking smoke before it starts to spread.

WIDER CHAMBER ENTRANCE

900mm wide chamber and a **415mm** depth distance buffer plate contain the spread of your cooking smoke in a confined area.

HIGHWAY FOR COOKING SMOKE

DIRECT-FLOW SYSTEM

Leads cooking smoke from chamber entrance to exhaust in one straight line with zero to minimal obstruction.

3-STAGE VERTICAL ACCELERATION

Let cooking smoke travels easily through smoke chamber.

SMART SYNC

Upon gas hob ignition, range hood automatically turns on to remove cooking smoke.

Needs to be paired with FOTILE's gas hob that has smart sync feature.

SMART SMOTION (SMOKE + MOTION) DETECTION

Turn the hood on and off with the wave of hand.

EASY TO CLEAN

Dual removeable grille filter for easy attachment and detachment when necessary.

LOW NOISE LEVEL

Uses Noise + Vibration + Harshness (NVH) system paired with BLDC motor and multiple noise-reduction technologies, the noise level produced is as low as **40dB**.

FOTILE SKYLIGHT

Skylight Above, Clear Air Beneath

92.2%

Oil Filtration Rate

97.5%

Odor Reduction Rate

Coated Steel Panel
Shock-absorbing Pad
Reflector Film
Light Guide Plate
Light Diffuser
Structural Adhesive Layer
High-clarity Grey Glass

BLDC
INVERTER MOTOR



NEW

35" SKYLIGHT SUCTION PLATE

WIDER LIGHT, BETTER VISIBILITY

Equipped with 685 x 273mm Skylight Suction Plate. The 35-inch design increases smoke capture area by **38.5%** and boosts smoke intake speed by **50%**.

Featuring a 7-layer material structure for superior light performance, durability, and easy cleaning. The 5000K neutral light creates a bright, uniform, shadow-free illumination that is comfortable on the eyes.

STRONGER EXTRACTION

BRUSHLESS DIRECT-CURRENT INVERTER (BLDC)

The BLDC motor boosts maximum static air pressure up to **1320Pa** with an unrestrained air flow of **2600m³/h** to remove cooking smoke while keeping noise level as low as **40dB**.

AUTO TURBO SYSTEM

Intelligent Airflow Algorithm 5.0 auto adjusts the motor speed and air pressure to ensure effective smoke extraction and prevent backflow.

HIDDEN SMOKE CONTROL DESIGN

Hidden smoke control design directs fumes into the suction path for more efficient extraction.

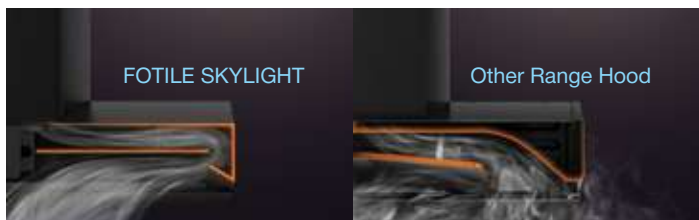

ERGONOMIC DESIGN

COMPACT FORM, GREATER COMFORT

Skylight range hood features a slim **470 mm** depth, giving you more room to move freely while cooking, prevents accidental head bumps.

SMART FRESH SYSTEM

Monitors kitchen air 24 hours a day, automatically detecting cooking odors, food waste smells, formaldehyde, gas leaks, and other harmful gases, fast air refresh in just 60 seconds.

SMART SYNC

Upon gas hob ignition, range hood automatically turns on to remove cooking smoke.

Needs to be paired with FOTILE's gas hob that has smart sync feature.

SMART SMOTION (SMOKE + MOTION) DETECTION

Turn the hood on and off with the wave of a hand.

EASY TO CLEAN

New filter-free structures and glass bodies can be cleaned easily with just wiping.

LOW NOISE LEVEL

Uses Noise + Vibration + Harshness (NVH) system paired with BLDC motor and multiple noise-reduction technologies, the noise level produced is as low as **40dB**.

FOTILE ✓

Clean-Air Tech



BLDC
INVERTER MOTOR



STRONGER EXTRACTION

BRUSHLESS DIRECT-CURRENT INVERTER (BLDC)

Doubling extraction power by achieving air pressure up to **1290Pa** with an unrestrained airflow of **2,100m³/h**.

AUTO TURBO SYSTEM

Increase extraction power automatically when resistance is detected.

SPACIOUS ENTRY CAVITY

580MM OPTIMAL COOKING SMOKE CONTROL ZONE

Fully trap cooking smoke before it starts to spread.

WIDER CHAMBER ENTRANCE

900mm chamber and a **310mm**-long plate contain the spread of your cooking smoke in a confined area.

INTELLIGENT SYSTEM

DELAY OFF TIMER

Hood will run for **2 minutes** to extract the remaining cooking smoke in your kitchen.

SMART SMOTION (SMOKE + MOTION) DETECTION

Turn the hood on and off with the wave of a hand.

SMART SYNC

Upon gas hob ignition, range hood automatically turns on to remove cooking smoke.

Needs to be paired with FOTILE's gas hob that has smart sync feature. Available in hood model JQG9009X and JQG9055-i.

HIGHWAY FOR COOKING SMOKE

DIRECT-FLOW SYSTEM

Leads cooking smoke from chamber entrance to exhaust in one straight line with zero to minimal obstruction.

3-STAGE VERTICAL ACCELERATION

Let cooking smoke travels easily through smoke chamber.

LOW NOISE LEVEL



HONEYCOMB-DESIGN FILTER & MICROPOROUS NOISE CANCELLATION TECHNOLOGY

Reduce high-frequency noise.



PATENTED NAUTILUS AIR PASSAGEWAY

Reduces both wind resistance and noise level.
Patent No. 01132056.7

EASY TO CLEAN

MAGNETIC FILTER & 135° ADJUSTABLE COVER

Easy filter attachment and detachment for quick, hassle-free access when cleaning the range hood. *Available in hood model JQG9055-i and JQG9031.*

EPS-I SERIES

GAS HOB

Smart Sync, Smart Flame

5.35kW

Heating Load

≥60%

Heating Efficiency

NEW

SMART SYNC

FLAMES IN, SMOKE OUT



Sync gas hob with range hood. Upon gas hob ignition, range hood automatically turns on to remove cooking smoke. *Needs to be paired with FOTILE's range hood that has smart sync feature. Available in hob model GEG88201.*

SMART FLAME

7+N ADJUSTABLE FLAME LEVELS

Easy to identify flame levels, from keeping food warm to stir-fry cooking.

5.35KW HIGH FLAME POWER

From lowest **0.28kW** to **5.35kW** high flame power. More than 60% heating efficiency for optimum level of flame for fast cooking with low gas consumption.

SMART TIMER



ACCURACY GUARANTEED

180-min timer. Constant monitoring is no longer needed. It automatically turns off the fire at desired time, eliminating the chaos in the cooking process. *Available in hob model GEG88201.*

EFFICIENT HEATING

REDUCE TIME CONSUMPTION BY **13.5%**

SAVE GAS CONSUMPTION BY **15%**

According to lab test result on boiling 1kg of water to 95°C by comparing EPS-i burner to other burners.

INSTANT IGNITION

FOTILE EPS-i is built for instant ignition, giving you roaring flames the moment you demand it.

ADJUSTABLE CUT-OUT SIZE

EASY INSTALLATION

With a customizable range of 700-840 (w) x 400-480mm (d), changing your hob is much easier.

SAFETY WITH FULL PROTECTION

Auto cut-off gas for continuous cooking up to 4 hours.

Available in hob model GEG88201.

4-layer explosion proof panel and **12 safety** features to safeguard you and your family.

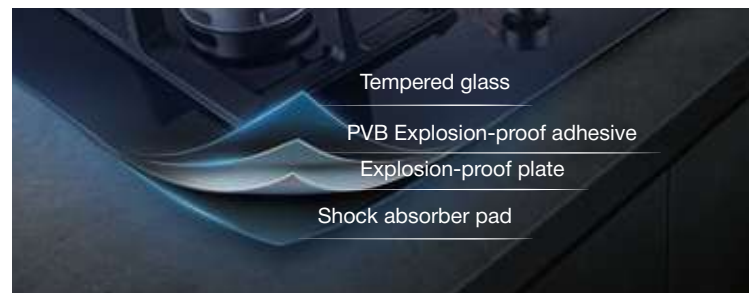

FROM STEWING TO STIR-FRYING, THE EPS-I BURNER CAN DO IT



Stewing



Simmering



Boiling



Stir-Frying



Deep-Frying

0.28kW

5.35kW

SUPERFLAME SERIES

GAS HOB

Smart Connection, Inspired Creation



Heating Load



Heating Efficiency



POWERFUL HEAT

5.0kW heating load, 60% heating efficiency. Powerful and fast cooking.

SAFE COOKING EXPERIENCE

12 safety features for a safer cooking experience.

STABLE PAN SUPPORT

The FOTILE Super Flame's 165mm pan support is designed to securely hold classic Southeast Asian sharp-bottomed woks, providing enhanced stability and an extra layer of safety.

DURABLE AGAINST RUST

High-quality aluminium alloy burner, long lasting and durable against rust.

FAST IGNITION

0-second ignition with fast ignition feature.

SAVE GAS CONSUMPTION

60% heating efficiency, saves 20% on gas consumption.

SMART SYNC

Sync gas hob with range hood. Upon gas hob ignition, range hood automatically turns on to remove cooking smoke.

Needs to be paired with FOTILE's range hood that has smart sync feature. Available in hob model GHG78221-i.

6 CORE TECHNOLOGIES



Pressure-stable pre-mixing chamber.



Oxygen augmenting fire cap.



Large flame hole.



Oxygen supplementation channel.



U5-balanced direct injection chamber.



Double-stabilized flame ring.

ADJUSTABLE CUT-OUT SIZE

EASY INSTALLATION

With a customizable range of 650-708 (w) x 350-400mm (d), changing your hob is much easier.

Available in hob model GHG78221-i, GHG78215 and GHG88215.

VITRO CERAMIC HOB

The Most Powerful In Its Class



MAXIMUM EFFICIENCY

Lower energy consumption and less heat loss for shorter cooking time and maximum efficiency. The hob is able to reach 598°C in just 4 minutes. Energy consumption from as low as RM0.22kWh**

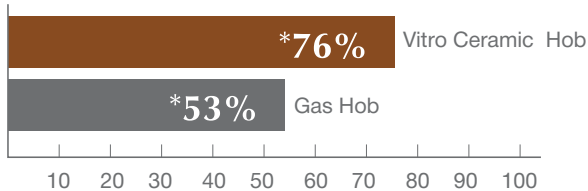

* FOTILE National Standard Lab Testing Result

**Based on current TNB tariff rate for residential usage & depending on individual household electricity consumption.

GERMAN QUALITY



SCHOTT CERAN GLASS

Able to resist high temperatures, making it extremely safe and durable.



E.G.O. HEATING COIL

Provides high standards in performance, excellent reliability and even heating.

VERSATILE AND CONVENIENT

With a **26cm** diameter, it offers a large cooking zone. Suitable for large pots and pans. Compatible for various kinds of cookware, including pans, pots, wok and ceramic products.



TOP-NOTCH SAFETY



Digital timer, child lock, overheating protection, safety off switch and high heat indicator.

DIGITAL TIMER

Lets you control the operation time for up to 9 hours and 59 minutes.

ELEGANT DESIGN

User-friendly interface with a sophisticated and elegant design.

EASY TO CLEAN

Just a wipe to restore to its original lustre.

INDUCTION HOB

For A Faster and Safer Cooking Experience



Heating Efficiency



REMOVABLE MAGNETIC KNOB



Operate with just a twist of knob. Lift the knob to pause the hob.

GERMAN QUALITY



SCHOTT CERAN GLASS

Able to resist high temperatures, making it extremely safe and durable.

TOP-NOTCH SAFETY



DIGITAL TIMER

Timer up to 99 mins



STANDBY MODE

Lift the knob to pause the hob



HIGH HEAT INDICATOR

When surface temperature is more than 55°C



SAFETY SWITCH OFF

Automatically switch off the hob if left idle for 2 hours



CHILD LOCK

Lock all buttons in the operational area



OVERHEATING PROTECTION

Shut down if pot dries up and temperature goes above 250°C



POT DETECTION

After burner heats up and no pans are in its place, it will shut down the appliances after 1 minute.



OVERHEATING PREVENTION

Lower power level to 300W for 1 minute if temperature reach 120°C within 30 sec

MAXIMUM EFFICIENCY

MORE THAN 88% HEATING EFFICIENCY

Delivers over 88% heating efficiency for faster heat-up, lower energy waste, and precision performance in every meal.

BOOST POWER

Give your cooking a boost with this function. It enable cooking zone to reach an extremely high temperature in 10 minutes.

9 POWER LEVELS

Cook a variety of dishes with 9 power levels.

3 CORE TECHNOLOGIES

4x MAGNETIC PROTECTION

More efficient and worry-free cooking experience.

LARGE HEATING ZONE

For even heating, copper coil boost efficiency.

DUAL-CORE CPU

Precise and faster execution.

KEEP WARM

Keep your food warm by keeping temperature in between 60~80°C for 2 hours.

EASY TO CLEAN

Just a wipe to restore to its original lustre.

KITCHEN DESIGN IDEAS

FOTILE X



FOTILE V



VERSATILE ELEGANCE KITCHEN

Transform your kitchen space into something that functions as beautifully as it looks.



COMBI OVEN
HZK46-TS3

RANGE HOOD
EMG9070-G

GAS HOB
GHG78221-i

SINK DISHWASHER
SD2F-P6

DISHWASHER
BD2BV01



RANGE HOOD
EMG9070-G
WM RM 3,650
EM RM3,750



GAS HOB
GHG78221-i
WM RM 1,870
EM RM1,950



COMBI OVEN
HZK46-TS3
WM RM 7,680
EM RM7,780



SINK DISHWASHER
SD2F-P6
WM RM 6,699
EM RM6,799



DISHWASHER
BD2BV01
WM RM 6,988
EM RM7,088

- 35" Skylight Suction Plate
- Hidden Smoke Control Design
- BLDC Inverter Motor
- Smart SMOTION Detection
- Smart Sync
- Smart Fresh System · Filter-free
- Auto Turbo System · Screen Lock
- Delay Off Function
- Unrestrained Airflow 2600m³/h
- IEC Airflow 1530m³/h
- Air Pressure 1320Pa
- Noise Level ≤45dB
- Oil Filtration Rate : 93.2%
- Odor Reduction Rate : 97.5%

- 78cm With 2-burner Gas Hob
- Smart Sync
- Heating Load (kW): L:5.0 R:5.0
- ≥60% Heating Efficiency
- Flexi Cut-out Size
- Safety Ignition Pin
- Flame Failure Device (FFD)
- Cast Iron Grate With Tempered Glass
- Fast Ignition
- Stable Pan Support

- AI Water Control · Dual Temperature Control
- Steam, Bake, Air Fry And Dehydrate
- 3 Layer Glass Door With Low-E
- Steam-Bake Smart Combo
- Auto Humidity Technology System
- 15 Cooking Modes · 7 Support Modes
- 60 Preset Programs
- 1300ml Water Tank, Continues Working Up To 90 Mins
- Superheated Steam Up To 120°C
- Proof, Keep Warm, Defrost, Schedule
- Power (kW): 3.4 · Capacity 46L
- To Be Connected Directly To A Min. 15A Circuit Breaker

- 3-in-1 Sink Dishwasher - Sink, Dishwasher, Fruits & Vegetable Purifier
- High Pressure Hydrojet Technology - 40,000Pa
- Automated Drainage System
- Triple Drying Technology · Fan Dry: 30 Mins
- 96 Hours Storage System
- Fits 55 Pieces Of Tablewares
- Food Grade 304 Stainless Steel Sink Material
- Waterproofing Capacitive Touch Screen
- Household Water Pressure: 0.14MPa - 1MPa
- Large Sink Size: 455mm (L) X 405mm (W) X 211mm (D)

- Smart Space Management System
- High Pressure Hydrojet Technology - 40,000Pa
- Dual Ventilation Drying · Fan Dry: 45mins
- Automated Drainage System
- 96 Hours Storage System
- 75°C High Temperature Sterilization
- Auto Clean Program
- Fits 15 Place Settings
- 6 Core + 4 Additional Programs
- Household Water Pressure: 0.14MPa - 1MPa
- Dishwasher Capacity 136L

**OPEN
HERE**

MICROWAVE OVEN
HW25800P-C2T



COMBI OVEN
HZK72-H1-i



THE GRAND KITCHEN

Imagine a kitchen not only defined by sophisticated style and luxurious finishes, but also equipped to deliver cooking solutions that cater to every Malaysian kitchen's needs.

RANGE HOOD
AMG9068



DISHWASHER
BD3B-G6-i



RANGE HOOD
AMG9068
WM RM 6,500
EM RM6,600



GAS HOB
GEG88201
WM RM 2,770
EM RM2,850



COMBI OVEN
HZK72-H1-i
WM RM 7,980
EM RM8,080



MICROWAVE OVEN
HW25800P-C2T
WM RM 3,399
EM RM3,499



DISHWASHER
BD3B-G6-i
WM RM 7,750
EM RM7,850

- BLDC Inverter Motor
- Smart SMOTION Detection
- Smart Sync
- Smart Air Diverter
- Rear Motor Extraction
- Auto Turbo System
- Screen Lock
- Delay Off Function
- Unrestrained Airflow 2800m³/h
- IEC Airflow 1600m³/h
- Air Pressure 1480Pa
- Noise Level ≤46dB
- Oil Filtration Rate: 92.9%
- Odor Reduction Rate: 98%

- 88cm With 2-burner Gas Hob
- Patented Jet Collision Technology
- Smart Sync
- Smart Timer Up To 180-min
- 7+n Adjustable Flame Levels
- Heating Load (kW) L: 5.35 R: 5.35
- ≥ 60% Heating Efficiency
- Flexi Cut-out Size
- Safety Ignition Pin
- Flame Failure Device (FFD)
- Cast Iron Grate With Tempered Glass
- Fast Ignition
- Low Battery Reminder
- Removable Washing Cap

- FOTILE Connect App - Scheduled Cooking , 200+ Cloud Recipes, Error Alerts, Status Preview
- Steam, Bake, Air Fry And Dehydrate
- 3 Layer Glass Door With Low-E
- Steam-Bake Smart Combo
- Auto Humidity Technology System
- 17 Cooking Modes · 6 Support Modes
- 55 Preset Programs
- 1200ml Water Tank, Continues Working Up To 120 Mins
- Superheated Steam Up To 120°C
- Proof, Keep Warm, Defrost
- Fast Ignition
- Multilayer Cooking · Power (kW): 3.4
- Capacity 72L
- To Be Connected Directly To A Min. 15A Circuit Breaker

- Flatbed Microwave
- Independent Ventilation System
- Illuminated 'O' Touch Screen
- Microwave And Grill Heating
- Child Lock Function
- 8 Express Cooking Menu
- Input Power (kW): Microwave 1.25 Grill 0.75
- Output Power (kW): 0.8
- Capacity 25L

- FOTILE Connect App - Scheduled Cleaning, Device Control, Error Alerts, Status Preview
- High Pressure Hydrojet Technology 3.0 – 50,000Pa
- Trio Ventilation Drying. Fan Dry: 20mins
- Automated Drainage System
- 99 Days Storage System
- 100°C Steam Sterilization · Self Cleaning Schedule
- Mother And Baby Care Wash · Claypot Wash
- Dish Warmer
- Knock Twice To Open · Smart Projection
- Fits 20 Place Settings
- 9 Core + 7 Additional Programs
- Household Water Pressure: 0.14MPa – 1MPa
- Dishwasher Capacity 164L

KITCHEN DESIGN IDEAS

FOTILE Z



SKYLIGHT W



COMBI OVEN

Healthy Cooking, Professional Results

FOTILE
CONNECT

NEW



Steam



Bake



Air Fry



Dehydrate

FOTILE ⁱ kitchen

CONNECT YOUR APPLIANCES

Available in combi oven model HZK72-H1-i.



Access **200+** constantly updated recipes with step-by-step instructions via FOTILE Connect App.



Schedule your cooking and come home to a hot meal, saving your time and effort.



Preview the status of your cooking remotely via FOTILE Connect App. The app will send error alerts to notify users of any abnormal issues, ensuring a safe and pleasant cooking experience.

STEAM-BAKE SMART COMBO

Steam dishes below while baking dishes above at the same time. Users can bake and steam food without being limited by sequential processes.

MULTILAYER COOKING

Simultaneously steam or bake multiple food at once. Easy to prepare meals for a family gathering, special occasions, or simply when batch cooking for the week.

STEAM

AI WATER CONTROL

Automatically adjusts and generates steam based on temperature and humidity levels. Available in combi oven model HZK46-TS3.

DYNAMIC STEAM BALANCED TECHNOLOGY

Ensure fresh steam supply and preserves the taste of your food.

BAKE

UNIFORM TEMPERATURE

Ensure that your food is baked evenly.

DUAL TEMPERATURE CONTROL

Cook two different dishes simultaneously with temperature difference up to 70°C. Available in combi oven model HZK46-TS3.

STEAM-BAKE

3 levels of humidity to choose. Retains the moisture of your food during baking.

AIR-FRYING

OIL-FREE COOKING

Fat removal rate up to **98%**. Dual fan high speed rotation with high temperature to remove excessive fat of your food, making your food crispier.

DEHYDRATE

PREVENTS OXIDATION OF FOOD

Dual fan high speed rotation with low temperature to prevent oxidation of food.

AUTO HUMIDITY TECHNOLOGY SYSTEM

Intelligently control top and back fan to maintain the most appropriate humidity in the cavity, ensuring the best cooking effect.

EASY TO CLEAN

Descaling cleaning, 100°C high-temperature steam clean, dry ventilation for chamber drying, and deodor mode to keep the oven cavity clean, fresh, and hygienic with minimal effort

AUXILIARY FUNCTIONS

Keep Warm, Defrost, and Proof help simplify daily cooking by keeping food warm, rapidly thawing frozen ingredients, and speeding up dough fermentation with ease.

ONE OVEN PLUS

One Oven To Cook It All



STEAM

4 STEAMING FUNCTIONS - LOW, NORMAL, HIGH, QUICK STEAM

Low steam of temperature as low as **30 °C** to high steam with temperature up to **120 °C**. Powerful steam generated in just **30-sec**. Quick steam assist in steaming frozen food without defrosting them. Preserves the taste and texture of your food.

DYNAMIC STEAM BALANCED TECHNOLOGY

Ensure fresh steam supply and preserves the taste of your food.

BAKING

5 BAKING MODES

Full Convection	Convect Bake	Top Bottom	Broil	Steam Bake
Top + Bottom Rear + Fan	Rear + Fan	Top + Bottom	Top	Top + Rear + Fan + Steam

DUAL TEMPERATURE CONTROL

Separately control top and bottom heating element. Temperature difference up to **30°C**. eg. Top 180°C, Bottom 150°C.

UNIFORM TEMPERATURE

Ensures that your food is baked evenly. Say goodbye to unstable temperature.

STEAM-BAKE

3 levels of humidity to choose. Retains the moisture of your food during baking.

AIR-FRYING

OIL-FREE COOKING

High speed hot air rotation - **2000r/min** with **98.6%** fat removal rate to remove excessive fat of your food, making your food crispier.

DEHYDRATE

PREVENTS OXIDATION OF FOOD

High speed hot air rotation – **2000r/min** to prevents oxidation of food.

HUMANIZED DESIGN

3 LAYER GLASS WITH LOW-E

Keep the door surface safe to touch during operation.

50+6 PRESET MENU

To cater all your cooking needs.

32L CAPACITY

Cook food of all shapes and sizes effortlessly.

EASY TO CLEAN

Descaling cleaning, 100°C high-temperature steam clean, dry ventilation, and deodor mode, the oven keeps the cavity clean, fresh, and hygienic with minimal effort while eliminating up to 99.99% of harmful bacteria with sterilization.

AUXILIARY FUNCTIONS

Jerky, Stew, Proof, Keep Warm, and Defrost allow you to dry meat, simmer soups and desserts for hours, ferment dough faster, keep food warm, and thaw frozen ingredients effortlessly

DISHWASHER

The Zero Hero



ZERO DIRT



HIGH PRESSURE HYDROJET TECHNOLOGY

Hundreds of billions of cavitation bubbles are continuously generated in water, accelerating the speed and momentum of the water flow to remove stubborn stains effectively. Inspired by the cleaning technology of the bottom of a submarine.

Patent No. 202211216010.X & 202010288660.X



BRUSHLESS DIRECT-CURRENT INVERTER (BLDC)

Provide a maximum **40,000 Pa** strong water pressure and adjusts according to different wash settings to provide a stable and powerful wash.



360° CLEANING WITH NO BLIND SPOTS

2 main spray arms + 2 supporting spray arms at the back of the chamber enhance cleaning effect by forming a 4-layer enveloping spray, alongside with 37 larger spray holes for a wider coverage to clean dishes.

ZERO ODOUR



AUTOMATED DRAINAGE SYSTEM

Water drainage is tilted for **15°** and automatically closes its valve after washing to prevent backflow of sewage, keeping dishwasher odourless and clean.

Patent No. 202023337590.7

ZERO WORRY

DUAL VENTILATION DRYING

Dual ventilation drying distributes heat evenly and effectively.

HIGH TEMPERATURE STERILIZATION

Eliminates **99.99%** of harmful bacteria under high temperature of **75°C**. *Patent No. 202121479074.X*

ZERO WASTE

SMART SPACE MANAGEMENT SYSTEM

It expands a partition and divide the chamber into upper and lower layer. Saves your water, time and energy consumption.

Applicable in dishwasher model BD2BV01. Patent No. 202010664979.8

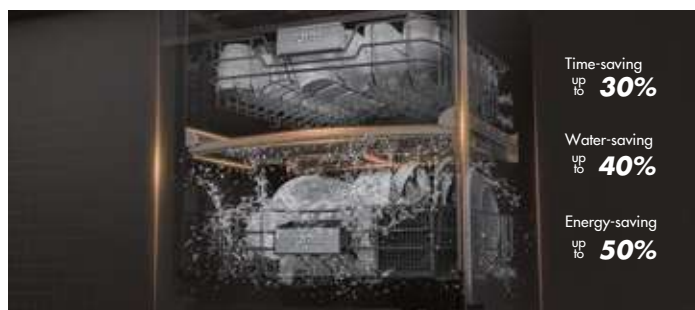

STORAGE FUNCTION

Automatic ventilation to keep your dishes dry after cleaning by providing continuous airflow during storage.

LOW NOISE LEVEL

Noise level as low as **42dB**.

AUTO MODE

Automatically detect the dirtiness level of your dishes to run the ideal cleaning program.

INNOVATIVE DESIGN

Auto-clean program to keep the dishwasher cavity clean and odourless, **6 core and 4 additional programs** to meet various needs, and a **30mm adjustable height** for flexible installation

I-KITCHEN DISHWASHER

Beyond Clean

FOTILE
CONNECT

NEW

FOTILE ⁱ kitchen CONNECT YOUR APPLIANCES

SMART CONTROL AND APP NOTIFICATION ALERT

With FOTILE Connect app, you can remotely schedule cleaning, adjust modes, and receive alerts for low dishwasher salt, detergent, and rinse aid anytime, anywhere.



Smart scheduling



Smart monitoring with real-time notifications

ADDITIONAL FUNCTIONS AND MODES

Additional functions and modes in FOTILE Connect app includes a 99-day Long-term Hygiene Storage Mode, Claypot Mode, Mother & Baby Care Wash, Self-clean, Sterilizing Drying, Wash-Dry-Store function, and Dish Warmer function.

All-CLEAN INTELLIGENT CLEANING SYSTEM



HIGH PRESSURE HYDROJET TECHNOLOGY 3.0 + ORBIT SYSTEM SPRAY ARMS

Effectively reaching, and cleaning the most challenging spots within your dishwasher.

AUTOMATED DRAINAGE SYSTEM



Water drainage is tilted for 15° and automatically closes its valve after washing to prevent backflow of sewage, keeping dishwasher odourless and clean. *Patent No. 202023337590.7*

TRIO VENTILATION DRYING

Dual hot air + 1 ambient air ventilation drying distributes heat evenly within your dishwasher.

100°C STEAM STERILIZATION

Eliminates 99.9999% of harmful bacteria.

FLEXIBLE RACK ARRANGEMENT

Dish racks offer dedicated spaces, accommodating larger items while providing designated areas for small utensils and specialized sections for irregular items like knives and spatulas.

SMART DESIGN

KNOCK TWICE TO OPEN

Simply give the door two quick knocks, and watch as it glides open effortlessly.

AUTODOSE+, AUTOMATIC DETERGENT DISPENSING SYSTEM

The liquid and rinse aid dispenser holds sufficient detergent for 15 washes.

SMART PROJECTION

Display the remaining time of the washing cycle. The projection light will only begin displaying the countdown once the door is securely closed and running.



LOW NOISE LEVEL

Noise level as low as 39dB

AUTO-CLEAN PROGRAM

Keeping dishwasher cavity clean & odourless.

AUTO MODE

Automatically detect the dirtiness level of your dishes to run the ideal cleaning program

SINK DISHWASHER

The World's 1st 3-in-1 Sink Dishwasher



product
design
award



99.99%

Sterilization Rate

>92%

Pesticide Residue
Removal Rate

ALL-CLEAN INTELLIGENT CLEANING SYSTEM



HIGH PRESSURE HYDROJET TECHNOLOGY

Hundreds of billions of cavitation bubbles are continuously generated in water, accelerating the speed and momentum of the water flow to remove stubborn stains effectively. Inspired by the cleaning technology of the bottom of a submarine.

Patent No. 202211216010.X & 202010288660.X



BRUSHLESS DIRECT-CURRENT INVERTER (BLDC)

Provide a maximum **40,000 Pa** strong water pressure and adjusts according to different wash settings to provide a stable and powerful wash.



360° CLEANING WITH NO BLIND SPOTS

FOTILE's sink dishwasher rotary spray is designed create a strong waterfall-like blanket of water for a more thorough cleaning. Eliminates **99.99%** of harmful bacteria under high temperature of **75°C**.

AUTOMATED DRAINAGE SYSTEM



Water drainage is tilted for 15° and automatically closes its valve after washing to prevent backflow of sewage, keeping dishwasher odourless and clean. *Patent No. 202023337590.7*

TRIPLE CONVECTION DRYING

Utilizes unique "**PTC hot air + residual heat + ventilation**" triple drying technology. After the washing cycle is complete, the door automatically opens, allowing hot air to blow in and accelerate drying. Internal moisture is naturally expelled, preventing it from being trapped inside the cabinet.

STORAGE FUNCTION

Automatic ventilation to store your dishes after cleaning up to **96 hours**.

PURIFIER FOR FRUITS & VEGETABLE

Remove all the harmful pesticides residues using HydroJet technology.

EXTRA LARGE SINK SIZE

The sink's dimensions are 455mm (w) x 405mm (d) x 211mm (h) providing plenty of room for your large pots and pans.

NO MORE BENDING DOWN

No more bending down to load dishes, the sink dishwasher is perfect for pregnant women and the elderly.

PERFECT FOR FAMILY

Fits up to 55 tablewares.

SAVE SPACE

Works as a sink, fruit and vegetable purifier and dishwasher, 3-in-1 appliances, saves your kitchen space.

RANGE HOOD

FOTILE X SERIES



RANGE HOOD
AMG9068

WM RM **6,500**
EM RM6,600

- BLDC Inverter Motor
- Smart SMOTION Detection
- Smart Sync
- Smart Air Diverter
- Rear Motor Extraction
- Auto Turbo System
- Screen Lock
- Delay Off Function
- Unrestrained Airflow 2800m³/h
- IEC Airflow 1600m³/h
- Air Pressure 1480Pa
- Noise Level ≤46dB
- Oil Filtration Rate: 92.9%
- Odor Reduction Rate: 98%



RANGE HOOD
AMG9007-i

WM RM **6,100**
EM RM6,200

- BLDC Inverter Motor
- Smart SMOTION Detection
- Smart Sync
- Smart Air Diverter
- Rear Motor Extraction
- Auto Turbo System
- Screen Lock
- Delay Off Function
- Unrestrained Airflow 1930m³/h
- IEC Airflow 1390m³/h
- Air Pressure 990Pa
- Noise Level ≤46dB
- Oil Filtration Rate: 92%
- Odor Reduction Rate: 97%

FOTILE Z SERIES



RANGE HOOD
ZMG9057

WM RM **4,700**
EM RM4,800

- BLDC Inverter Motor
- Smart SMOTION Detection
- Smart Sync
- Intelligent Air Management
- Dual Removeable Grill Filter
- Auto Turbo System
- Delay Off Function
- Unrestrained Airflow 2450m³/h
- IEC Airflow 1580m³/h
- Air Pressure 1140Pa
- Noise Level ≤48dB
- Oil Filtration Rate : 92%
- Odor Reduction Rate : 97%



RANGE HOOD
ZMG9056

WM RM **4,700**
EM RM4,800

- BLDC Inverter Motor
- Smart SMOTION Detection
- Smart Sync
- Intelligent Air Management
- Dual Removeable Grill Filter
- Auto Turbo System
- Delay Off Function
- Unrestrained Airflow 2450m³/h
- IEC Airflow 1510m³/h
- Air Pressure 1170Pa
- Noise Level ≤49dB
- Oil Filtration Rate : 92%
- Odor Reduction Rate : 97%

SKYLIGHT



RANGE HOOD
EMG9070-G

WM RM **3,650**
EM RM3,750

- 35" Skylight Suction Plate
- Hidden Smoke Control Design
- BLDC Inverter Motor
- Smart SMOTION Detection
- Smart Sync
- Smart Fresh System
- Depth : 470mm · Filter-free
- Auto Turbo System
- Screen Lock · Delay Off Function
- Unrestrained Airflow 2600m³/h
- IEC Airflow 1530m³/h
- Air Pressure 1320Pa
- Noise Level ≤45dB
- Oil Filtration Rate : 93.2%
- Odor Reduction Rate : 97.5%

FOTILE V SERIES



RANGE HOOD
JQG9009X

WM RM **5,500**
EM RM5,600

- BLDC Inverter Motor
- Smart SMOTION Detection
- Smart Sync
- 3-layer Centrifugal Filter + Oil Free Technology
- Dual Removeable Grill Filter
- Auto Turbo System
- Screen Lock · Delay Off Function
- Memory Function
- Unrestrained Airflow 2100m³/h
- IEC Airflow 1440m³/h
- Air Pressure 1290Pa
- Noise Level ≤52dB
- Oil Filtration Rate: 95%
- Odor Reduction Rate: 98%



RANGE HOOD
JQG9055-i

WM RM **4,500**
EM RM4,600

- BLDC Inverter Motor
- Smart SMOTION Detection
- Smart Sync
- Unique Magnet Grease Filter
- Auto Turbo System
- Screen Lock · Delay Off Function
- Unrestrained Airflow 2000m³/h
- IEC Airflow 1420m³/h
- Air Pressure 1050Pa
- Noise Level ≤55dB
- Oil Filtration Rate: 95%
- Odor Reduction Rate: 98.8%



RANGE HOOD
JQG9031

WM RM **3,700**
EM RM3,800

- Smart Smotion Detection
- 180-sec Turbo System
- Unique Magnet Grease Filter
- Screen Lock
- Delay Off Function
- Unrestrained Airflow 1750m³/h
- IEC Airflow 1340m³/h
- Air Pressure 460Pa
- Noise Level ≤55dB
- Oil Filtration Rate : 95%
- Odor Reduction Rate: 98%

FOTILE W SERIES



RANGE HOOD
EMG9035

WM RM **4,600**
EM RM4,700

- BLDC Inverter Motor
- Smart SMOTION Detection
- Patented Wing-like Surround Suction Plate
- Auto Turbo System
- Screen Lock · Delay Off Function
- Unrestrained Airflow 1950m³/h
- IEC Airflow 1420m³/h
- Air Pressure 880Pa
- Noise Level ≤48dB
- Oil Filtration Rate : 92%
- Odor Reduction Rate : 97%



RANGE HOOD
EMG9037

WM RM **2,790**
EM RM2,890

- Smart SMOTION Detection
- 180-sec Turbo System
- Patented Wing-like Surround Suction Plate
- Rounded Edge
- Delay Off Function
- Unrestrained Airflow 1600m³/h
- IEC Airflow 1240m³/h
- Air Pressure 420Pa
- Noise Level ≤54dB
- Oil Filtration Rate : 92%
- Odor Reduction Rate : 97%



RANGE HOOD
EMS9028S

WM RM **2,790**
EM RM2,890

- Smart SMOTION Detection
- 180-sec Turbo System
- Patented Wing-like Surround Suction Plate
- Rounded Edge
- Delay Off Function
- Unrestrained Airflow 1500m³/h
- IEC Airflow 1210m³/h
- Air Pressure 430Pa
- Noise Level ≤56dB
- Oil Filtration Rate : 92%
- Odor Reduction Rate : 97%



RANGE HOOD
EMG9008-CR

WM RM **3,800**
EM RM3,900

- Recirculation Hood
- BLDC Inverter Motor
- Smart SMOTION Detection
- 100-sec Turbo System
- Oil Filtration Rate : 96%
- Patented Wing-like Surround Suction Plate
- Carbon Filter With 10.5mm Buffer Space With Outer Aluminium Filter
- Filter Replacement Notification After 150-450 Hours · Delay Off Function
- Unrestrained Airflow 1400m³/h
- IEC Airflow 920m³/h
- Air Pressure 850Pa
- Noise Level ≤53dB
- Odor Reduction Rate : 98%

IEC WHAT IS IEC?

It is an international standard and conformity assessment body for all fields of electronics standard, cooker hood airflow should have this standard number (IEC 61591)

GAS HOB

EPS-i SERIES



GAS HOB
GEG88201
WM RM **2,770**
EM RM2,850

- 88cm With 2-burner Gas Hob
- Patented Jet Collision Technology
- Smart Sync
- Smart Timer Up To 180-min
- 7+n Adjustable Flame Levels
- Heating Load (kW) L: 5.35 R: 5.35
- ≥ 60% Heating Efficiency
- Flexi Cut-out Size
- Safety Ignition Pin
- Flame Failure Device (FFD)
- Cast Iron Grate With Tempered Glass
- Fast Ignition
- Low Battery Reminder
- Removable Washing Cap



GAS HOB
GEG88306-i
WM RM **2,970**
EM RM3,050

- 88cm With 3-burner Gas Hob
- Patented Jet Collision Technology
- Smart Sync
- 7+n Adjustable Flame Levels
- Heating Load (kW): L:5.35 M: 1.70 R:5.35
- ≥60% Heating Efficiency
- Flexi Cut-out Size
- Safety Ignition Pin
- Flame Failure Device (FFD)
- Cast Iron Grate With Tempered Glass
- Fast Ignition
- Low Battery Reminder
- Removable Washing Cap

TRI-RING SERIES



GAS HOB
GLS36503
WM RM **5,500**
EM RM5,600

- 91cm With 5-burner Gas Hob
- Tri-rings Flame
- Top Air Intake
- Heating Load (kW): LR:1.6 LF:3.4 C:5 RR:0.7 RF:3.4
- Safety Ignition Pin
- Flame Failure Device (FFD)
- Brass Material Burner
- 304 Stainless Steel Surface
- Fast Ignition
- To Be Connected Directly To A Min. 13A Circuit Breaker

SUPER FLAME SERIES



GAS HOB
GHG78221-i
WM RM **1,870**
EM RM1,950

- 78cm With 2-burner Gas Hob
- Smart Sync
- Heating Load (kW): L:5.0 R:5.0
- ≥60% Heating Efficiency
- Flexi Cut-out Size
- Safety Ignition Pin
- Flame Failure Device (FFD)
- Cast Iron Grate With Tempered Glass
- Fast Ignition
- Stable Pan Support

SUPER FLAME SERIES



GAS HOB
GHG73201
WM RM **1,370**
EM RM1,450

- 73cm With 2-burner Gas Hob
- Heating Load (kW): L:5.0 R:5.0
- ≥60% Heating Efficiency
- Safety Ignition Pin
- Flame Failure Device (FFD)
- Cast Iron Grate With Tempered Glass
- Fast Ignition
- Low Battery Reminder
- Heat Shield Pan Support



GAS HOB
GHG78215
WM RM **1,770**
EM RM1,850

- 78cm With 2-burner Gas Hob
- Heating Load (kW): L:5.0 R:5.0
- ≥60% Heating Efficiency
- Flexi Cut-out Size
- Safety Ignition Pin
- Flame Failure Device (FFD)
- Cast Iron Grate With Tempered Glass
- Fast Ignition
- Low Battery Reminder
- Removable Washing Cap



GAS HOB
GHG78312
WM RM **2,070**
EM RM2,150

- 78cm With 3-burner Gas Hob
- Heating Load (kW): L: 5.0 M: 1.7 R: 5.0
- ≥60% Heating Efficiency
- Safety Ignition Pin
- Flame Failure Device (FFD)
- Cast Iron Grate With Tempered Glass
- Fast Ignition
- Low Battery Reminder
- Removable Washing Cap



GAS HOB
GHG88215
WM RM **2,570**
EM RM2,650

- 88cm With 2-burner Gas Hob
- Heating Load (kW): L: 5.0 R: 5.0
- ≥60% Heating Efficiency
- Flexi Cut-out Size
- Safety Ignition Pin
- Flame Failure Device (FFD)
- Cast Iron Grate With Tempered Glass
- Fast Ignition
- Low Battery Reminder
- Removable Washing Cap

ELECTRIC HOB

CERAMIC



CERAMIC HOB
EEG75201
WM RM **3,970**
EM RM4,050

- Made-in-Germany SCHOTT CERAN® Ceramic Glass Surface
- Made-in-germany E.G.O Electric Radiation Technology
- 3 Heat Radiation Heating Zones
- 1-5 Power Level
- Touch Control
- Easy To Clean
- Timer : 1-599min
- Heating Load (kW): Total 4.5kW L: 0.2 - 1 (Inner Ring Only), 0.44 - 2.2 (Inner + Outer Rings) R: 0.46 - 2.3 (Inner + Outer Rings)
- To Be Connected Directly To A Min. 20A Circuit Breaker



CERAMIC HOB
EEG60301
WM RM **3,790**
EM RM3,870

- Made-in-Germany SCHOTT CERAN® Ceramic Glass Surface
- Made-in Germany E.G.O Electric Radiation Technology
- 4 Heat Radiation Heating Zones
- 1-9 Power Levels
- Touch Control
- Easy To Clean
- Timer: 1-99min
- Heating Load (kW): Total: 5.2kW L-upper: 1.8 L-bottom: 1.2 R: 2.2
- To Be Connected Directly To A Min. 25A Circuit Breaker

INDUCTION



INDUCTION HOB
EIG76203
WM RM **4,370**
EM RM4,450

- Made-in-Germany SCHOTT CERAN® Ceramic Glass Surface
- 4x Magnetic Protection
- 8 Safety Features
- Dual-core CPU
- Boost & Keep Warm Function
- Removable Magnetic Knob
- 1-9 Power Levels
- Timer: 1-99min
- Heating Load (kW): Total 3.4kW L: 3.0 R: 3.0
- To Be Connected Directly To A Min. 16A Circuit Breaker

HYBRID



HYBRID HOB
MEG70201
WM RM **3,800**
EM RM3,880

- Made-in-germany SCHOTT CERAN® Ceramic Glass Surface
- 22 Power Levels (100W To 2200W)
- 5 Safety Features
- Touch Control
- Timer: 10 Hours
- Pause & Keep Warm Function
- Suitable For Different Types Of Cookware for Ceramic Hob
- ≥86% Heating Efficiency
- Heating Load (kW): Total 3.6kW L: 2.2 R: 2.2
- To Be Connected Directly To A Min. 16A Circuit Breaker

DOMINO HOB

GAS HOB



**GAS HOB
GEG30103**

WM RM **1,350**
EM RM1,430

- 33cm With 1-burner Gas Hob
- Heating Load (kW): 5.35
- ≥60% Heating Efficiency
- Patented Jet Collision Technology
- Safety Ignition Pin
- Flame Failure Device (FFD)
- Fast Ignition
- Cast Iron Grate With Tempered Glass
- Removable Washing Cap

CERAMIC HOB



**CERAMIC HOB
D7RW**

WM RM **1,780**
EM RM1,860

- Made-in Germany SCHOTT CERAN® Ceramic Glass Surface
- Made-in Germany E.G.O Electric Radiation Technology
- 2 Heat Radiation Heating Zones
- 1-9 Power Levels
- Touch Control
- Easy To Clean
- Timer : 1-99min
- Heating Load (kW): 2.4
- To Be Connected Directly To A Min. 13A Circuit Breaker



**CERAMIC HOB
EEG30202**

WM RM **2,450**
EM RM2,530

- Made-in Germany SCHOTT CERAN® Ceramic Glass Surface
- Made-in Germany E.G.O Electric Radiation Technology
- 3 Heat Radiation Heating Zones
- 1-9 Power Levels
- Touch Control
- Easy To Clean
- Timer: 1-99min
- Heating Load (kW): Total: 2.9kW Upper: 1.7 ; Bottom: 1.2
- To Be Connected Directly To A Min. 15A Circuit Breaker

INDUCTION HOB



**INDUCTION HOB
EIG30102**

WM RM **2,450**
EM RM2,530

- Made-in-germany SCHOTT CERAN® Glass Surface
- 4x Magnetic Protection
- 7 Safety Features
- Dual-core CPU
- Boost & Keep Warm Function
- 1-9 Power Levels
- Timer: 1-99min
- Heating Load (kW): 3.0
- To Be Connected Directly To A Min. 15A Circuit Breaker

OVEN

OVEN



**OVEN
KSG7007A**

WM RM **3,880**
EM RM3,980

- 8 Cooking Functions
- Removeable Triple Glazed Door With Low E-glass
- Easy Operation With Mechanical Control
- Beginner Friendly Cooking Tips
- 3 Japanese Heating Tubes
- Anti-spill Grill For Increased Safety
- Front Ventilation System
- Fermentation · Power (kW): 2.8
- Capacity 70L
- To Be Connected Directly To A Min. 15A Circuit Breaker

COMBI OVEN



**COMBI OVEN
HZK72-H1-i**

WM RM **7,980**
EM RM8,080

- FOTILE Connect App - Scheduled Cooking, 200+ Cloud Recipes, Error Alerts, Status Preview
- Steam, Bake, Air Fry And Dehydrate
- 3 Layer Glass Door With Low-E
- Steam-Bake Smart Combo
- Auto Humidity Technology System
- Multilayer Cooking
- 17 Cooking Modes · 6 Support Modes
- 55 Preset Programs
- 1200ml Water Tank, Continues Working Up To 120 Mins
- Superheated Steam Up To 120°C
- Proof, Keep Warm, Defrost
- Power (kW): 3.4 · Capacity 72L
- To Be Connected Directly To A Min. 15A Circuit Breaker

ONE OVEN



**ONE OVEN
HYZK26-E1**

WM RM **3,199**
EM RM3,299

- Steam, Bake, Air Fry And Dehydrate
- 3 Layer Glass Door With Low-E
- Freestanding Oven
- 10 Cooking Modes
- 3 Cleaning Modes
- 40 Preset Cooking Programs
- 900ml Water Tank, Continues Working Up To 96 Mins
- Superheated Steam Up To 110°C
- Proof, Keep Warm
- Dimension W X D X H (mm): 451 X 478 X 355
- Power (kW): 2.1
- Capacity 26L



**ONE OVEN PLUS
HYZK32-E3**

WM RM **3,799**
EM RM3,899

- Steam, Bake, Air Fry And Dehydrate
- 3 Layer Glass Door With Low-E
- Freestanding Oven
- Dual Temperature Control
- 15 Cooking Modes
- 5 Cleaning Modes
- 50+6 Preset Cooking Programs
- 900ml Water Tank, Continues Working Up To 90 Mins
- Superheated Steam Up To 120°C
- Stew, Proof, Keep Warm, Defrost, Sterilization, Deodor
- Dimension W X D X H (mm): 474 X 512 X 375
- Power (kW): 2.15
- Capacity 32L

MICROWAVE OVEN



**MICROWAVE OVEN
HW25800K-03G**

WM RM **2,999**
EM RM3,099

- Independent Ventilation System
- Microwave And Grill Heating
- Touch Control
- Child Lock Function
- Wide LED Screen Display
- 8 Express Cooking Menu
- Input Power (kW): Microwave: 1.35 Grill: 0.85
- Output Power (kW): 0.8
- Capacity 25L

ROSE GOLD SERIES



OVEN
KSG7003AT

WM RM **5,300**
EM RM5,400

- 11 Cooking Functions
- Illuminated 'O' Touch Screen
- Removeable Triple Glazed Door With Double Low E-glass
- LED Digital Display With Touch Control
- Beginner Friendly Cooking Tips
- Child Lock Function And Timer
- Damping Hinge For Soft Closing
- Hot Air Filter And 5 Japanese Heating Tubes
- Fermentation . Power (kW): 3.2
- Capacity 70L
- To Be Connected Directly To A Min. 15A Circuit Breaker



COMBI OVEN
HZK46-TS3

WM RM **7,680**
EM RM7,780

- Steam, Bake, Air Fry And Dehydrate
- 3 Layer Glass Door With Low-E
- AI Water Control
- Dual Temperature Control
- Auto Humidity Technology System
- Multilayer Cooking
- 13 Cooking Modes . 6 Support Modes
- 60 Preset Programs
- 1300ml Water Tank, Continues Working Up To 90 Mins
- Superheated Steam Up To 120°C
- Proof, Keep Warm, Defrost, Schedule
- Power: 3.4kw
- Capacity 46L
- To Be Connected Directly To A Min. 15A Circuit Breaker



STEAM OVEN
SCD42-C2T

WM RM **5,800**
EM RM5,900

- Dual-effect Steam Technology, Fast Heating
- Illuminated 'O' Touch Screen
- Anti-condensation Technology
- Dynamic Steam Balance System
- 1.4 Litre Water Tank
- 8 Preset Programs
- Continuous Steam For 120mins
- Power (kW): 2.2
- Capacity 42L



MICROWAVE OVEN
HW25800P-C2T

WM RM **3,399**
EM RM3,499

- Flatbed Microwave
- Independent Ventilation System
- Illuminated 'O' Touch Screen
- Microwave And Grill Heating
- Child Lock Function
- 8 Express Cooking Menu
- Input Power (kW): Microwave - 1.25
Grill - 0.75
- Output Power (kW): 0.8
- Capacity 25L



DISHWASHER
BD2BV01

WM RM **6,988**
EM RM7,088

- Smart Space Management System
- High Pressure Hydrojet Technology: 40,000Pa
- Dual Ventilation Drying . Fan Dry: 45mins
- Automated Drainage System
- 96 Hours Storage System
- 75°C High Temperature Sterilization
- Auto Clean Program
- Fits 15 Place Settings
- 6 Core + 4 Additional Programs
- Household Water Pressure: 0.14MPa - 1MPa
- Dishwasher Capacity 136L

DISHWASHER

DISHWASHER



DISHWASHER
BD3B-G6-i

WM RM **7,750**
EM RM7,850

- FOTILE Connect App - Scheduled Cleaning, Device Control, Error Alerts, Status Preview
- High Pressure Hydrojet Technology 3.0: 50,000Pa
- Trio Ventilation Drying. Fan Dry: 20mins
- Automated Drainage System
- 99 Days Storage System
- 100°C Steam Sterilization · Self Cleaning Schedule
- Mother And Baby Care Wash · Claypot Wash
- Dish Warmer
- Knock Twice To Open · Smart Projection
- Fits 20 Place Settings
- 9 Core + 7 Additional Programs
- Household Water Pressure: 0.14MPa - 1MPa
- Dishwasher Capacity 164L



DISHWASHER
BD2B-G5

WM RM **4,688**
EM RM4,788

- High Pressure Hydrojet Technology: 34,000Pa
- Dual Ventilation Drying. Fan Dry: Up To 45mins
- Automated Drainage System
- 96 Hours Storage System
- 75°C High-temperature Sterilization
- Fits 12 Place Settings
- 6 Core + 3 Additional Programs
- Household Water Pressure: 0.14MPa - 1MPa
- Dishwasher Capacity 101L

SINK DISHWASHER



SINK DISHWASHER
SD2F-P6

WM RM **6,699**
EM RM6,799

Faucet is not included

- 3-in-1 Sink Dishwasher - Sink, Dishwasher, Fruits & Vegetable Purifier
- High Pressure Hydrojet Technology: 40,000Pa
- Triple Drying Technology . Fan Dry: 30 Mins
- Automated Drainage System
- 96 Hours Storage System
- 75°C High-temperature Sterilization
- Fits 55 Pieces Of Tablewares
- Food Grade 304 Stainless Steel Sink Material
- Waterproofing Capacitive Touch Screen
- Household Water Pressure: 0.14MPa - 1MPa
- Large Sink Size: 455mm (L) X 405mm (W) X 211mm (D)

INSTALLATION DIAGRAM

SINK DISHWASHER SD2F-P6

BEFORE INSTALLATION REQUIREMENT:

1. The outlet (drainage) pipe must be $\leq 350\text{mm}$ from the ground, pipe diameter $\geq 50\text{mm}$
2. Table top cut-out size must be ready before installation
3. Prepare a 13amp power point inside the cabinet
- ★ 4. Installation type : Top mount only

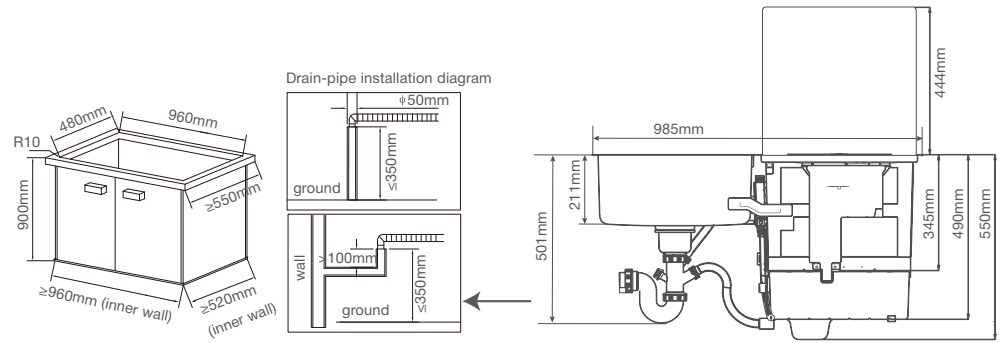

DISHWASHER BD2BV01 BD3B-G6-i

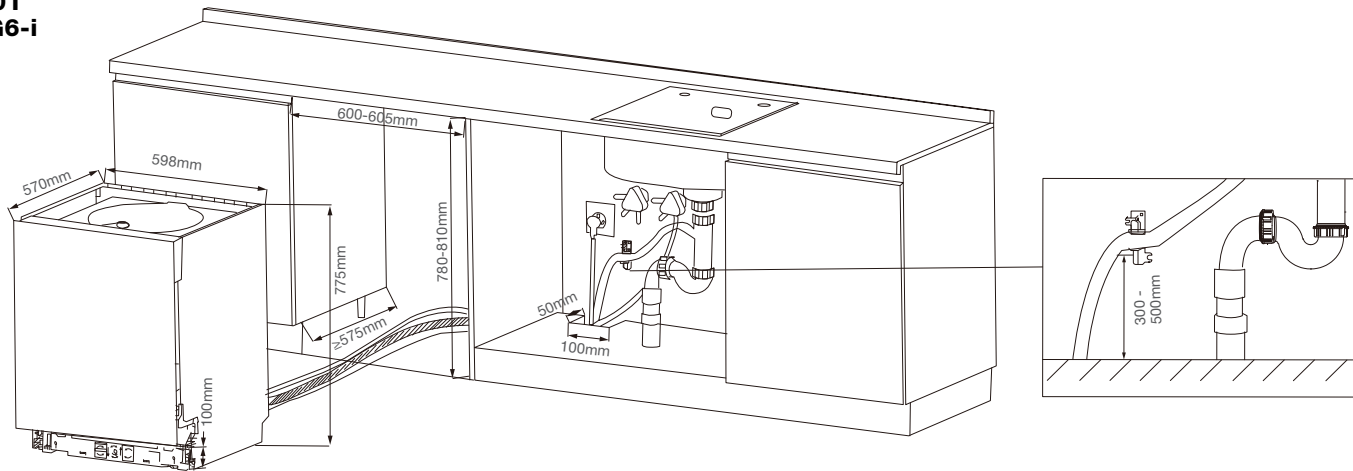

DISHWASHER BD2B-G5

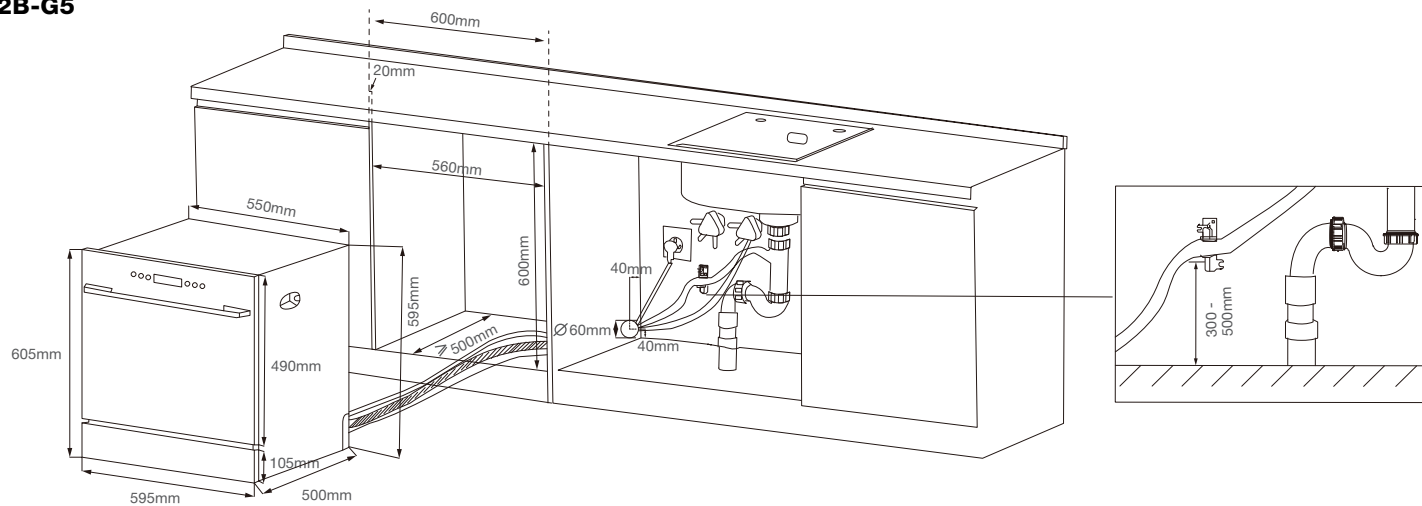

BEFORE INSTALLATION REQUIREMENT:

1. The outlet (drainage) pipe & water inlet must be near to dishwasher.
2. The drain hose hook from the ground must be at least 300 mm ~ 500 mm.
3. Cabinet cut-out size must be ready before installation
4. Prepare a 13amp power point inside the cabinet.
5. Do not place any objects to block the ventilation outlet at bottom front of dishwasher.
6. If there is a base of cabinet, it must be strong enough to withstand more than 60kg.
7. Recommended to prepare skirting board for bottom of dishwasher.
8. For BD3B-G6-i Dishwasher, it must be installed according to the Figure 1.1

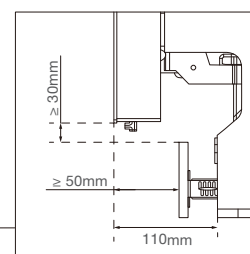
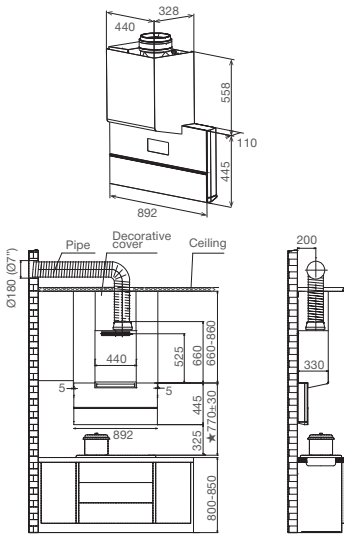

Figure 1.1

INSTALLATION DIAGRAM

HOOD
AMG9068



* Distance is calculated from the pan support of hob

HOOD
AMG9007-i

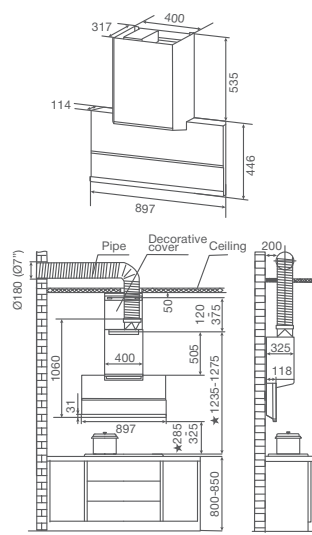

* Distance is calculated from the pan support of hob

HOOD
ZMG9056 / ZMG9057

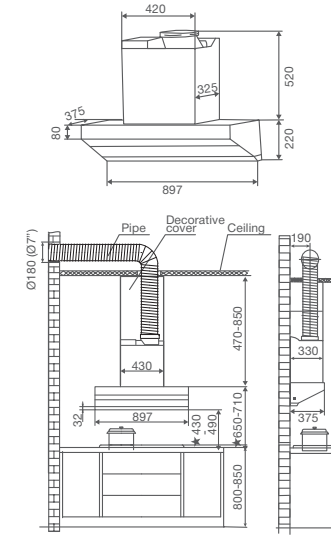

* Distance is calculated from the pan support of hob

HOOD
EMG9070-G

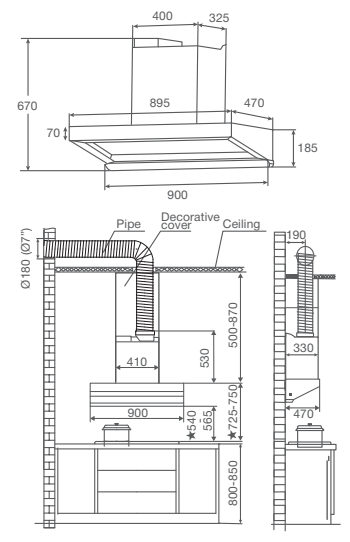

* Distance is calculated from the pan support of hob

HOOD
JQG9009X

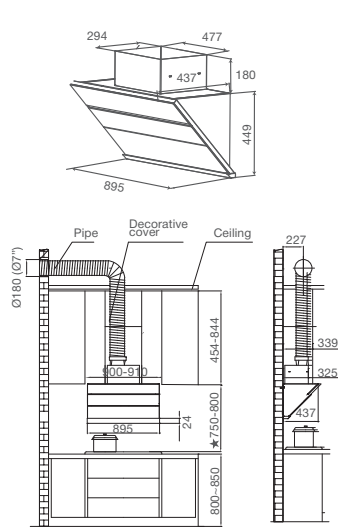

* Distance is calculated from the pan support of hob

HOOD
JQG9055-i

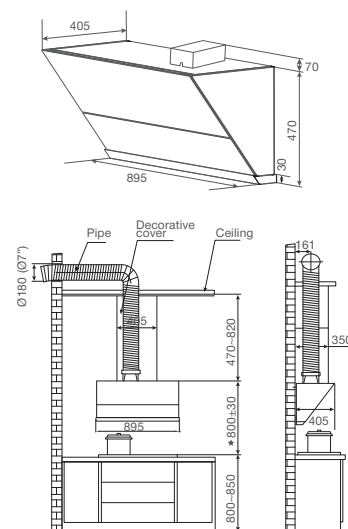

* Distance is calculated from the pan support of hob

HOOD
JQG9031

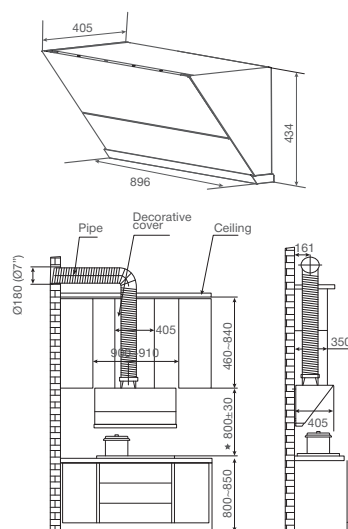

* Distance is calculated from the pan support of hob

HOOD
EMG9035

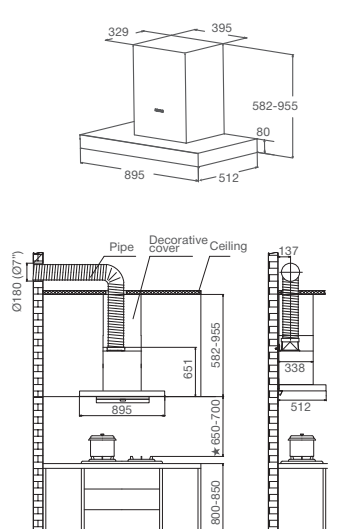

* Distance is calculated from the pan support of hob

HOOD
EMG9037

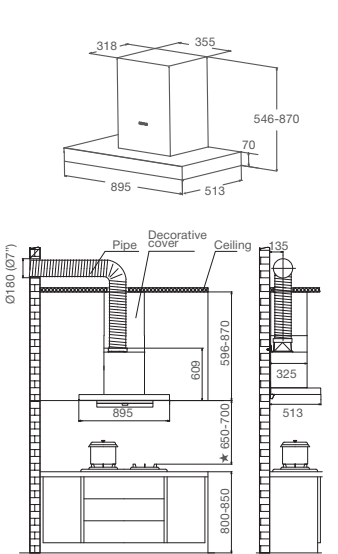

* Distance is calculated from the pan support of hob

HOOD
EMS9028S

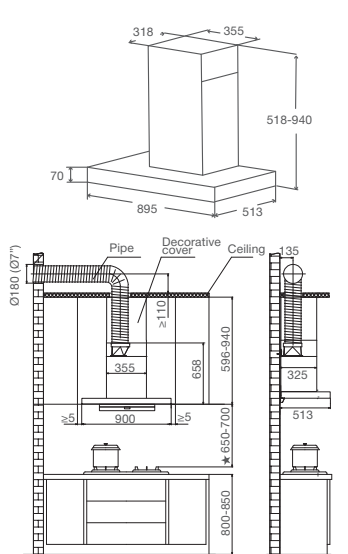

* Distance is calculated from the pan support of hob

HOOD
EMG9008-CR

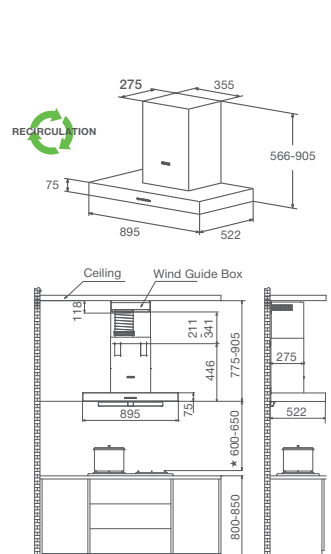

* Distance is calculated from the pan support of hob

HOB
GEG88201
GEG88306-i
GHG88215

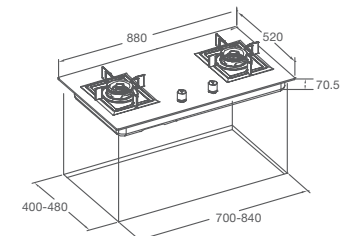

HOB
GHG73201

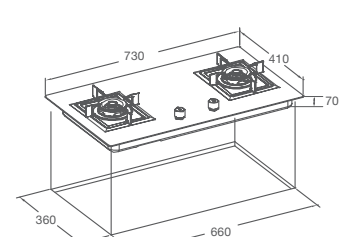

· ALL FOTILE DUCTED HOOD MUST HAVE A DUCTING HOLE OPENING OF 7" / 180MM DIAMETER
· ALL UNIT MEASUREMENTS ARE IN MILLIMETERS (MM) UNLESS STATED OTHERWISE

INSTALLATION DIAGRAM

HOB
GHG78215
GHG78221-i

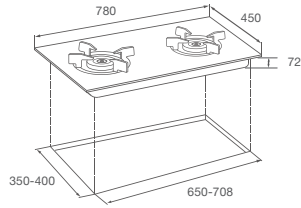

HOB
GHG78312

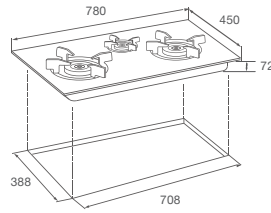

HOB
GLS36503

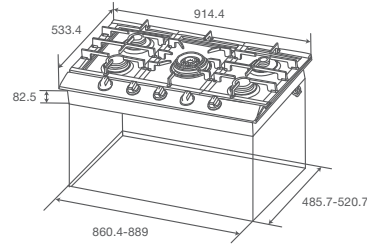

HOB
EIG76203

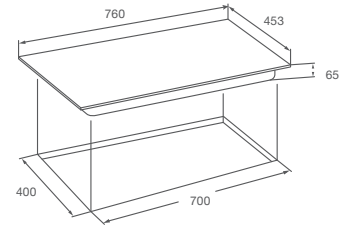

TO BE CONNECTED DIRECTLY TO A MIN. 16AMP CIRCUIT BREAKER

HOB
EEG75201

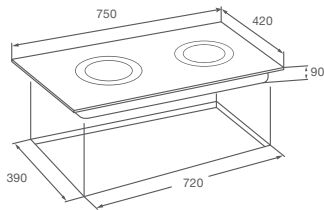

TO BE CONNECTED DIRECTLY TO A MIN. 20AMP CIRCUIT BREAKER

HOB
GEG30103

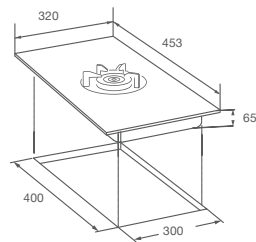

HOB
D7RW
EIG30102

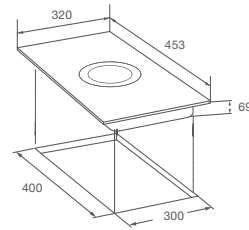

D7RW: TO BE CONNECTED DIRECTLY TO A MIN. 13AMP CIRCUIT BREAKER
EIG30102: TO BE CONNECTED DIRECTLY TO A MIN. 15AMP CIRCUIT BREAKER

HOB
EEG30202

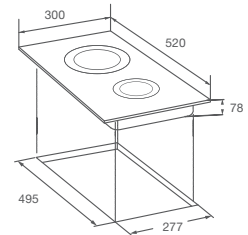

TO BE CONNECTED DIRECTLY TO A MIN. 15AMP CIRCUIT BREAKER

HOB
EEG60301

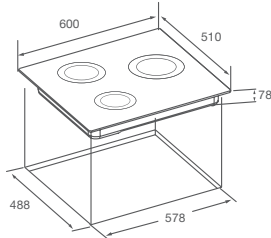

TO BE CONNECTED DIRECTLY TO A MIN. 25AMP CIRCUIT BREAKER

HOB
MEG70201

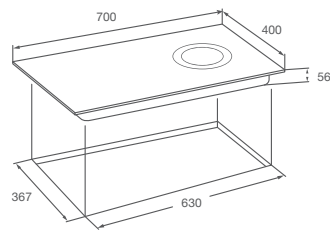

TO BE CONNECTED DIRECTLY TO A MIN. 16AMP CIRCUIT BREAKER

STEAM OVEN
SCD42-C2T

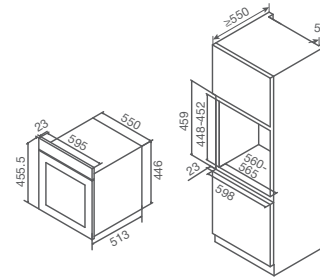

MICROWAVE OVEN
HW25800K-03G
HW25800P-C2T

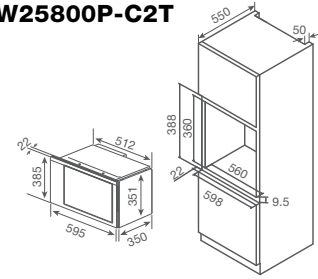

OVEN
KSG7007A
KSG7003AT

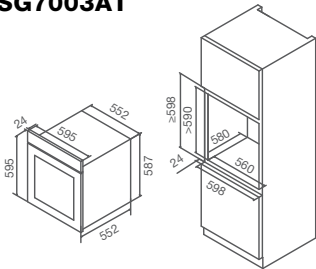

TO BE CONNECTED DIRECTLY TO A MIN. 15AMP CIRCUIT BREAKER

COMBI OVEN
HZK46-TS3

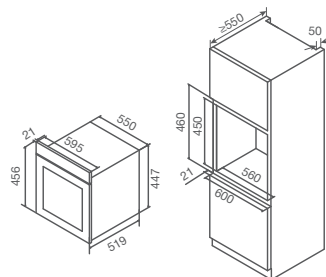

TO BE CONNECTED DIRECTLY TO A MIN. 15AMP CIRCUIT BREAKER

COMBI OVEN
HZK72-H1-i

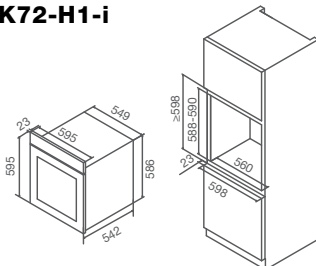

TO BE CONNECTED DIRECTLY TO A MIN. 15AMP CIRCUIT BREAKER

HOOD ACCESSORY

HONEYCOMB RECIRCULATION KIT

Available for all hood models except for EMG9008-CR

RCP

RM 198

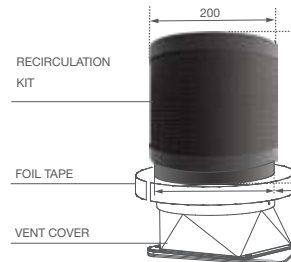

- Oil filtration rate 96.9%
- High density activated carbon content
- 2.4x carbon mesh density with 20mm thickness
- Non-stick coating for hassle-free cleaning
- Filter replacement after 180 hours of usage
- ★ Recommended only for users that cannot do ducting in their kitchen

1. VENT COVER IS NOT INCLUDED IN THE HONEYCOMB RECIRCULATION KIT.
2. RECOMMENDED ONLY FOR USERS THAT CANNOT DO DUCTING IN THEIR KITCHEN.
3. HONEYCOMB RECIRCULATION KIT NEED TO BE CHANGE EVERY 180 HOURS.
4. RECOMMENDED TO KEEP UPPER CABINET DOOR OPEN OR ENSURE ENOUGH VENTILATION INSIDE CABINET WHEN YOU USE HONEYCOMB RECIRCULATION KIT.

HAPPINESS STARTS IN YOUR KITCHEN

FOTILE MARKETING SDN BHD

  FOTILEMalaysia

 03-8602 9289 (HQ)

 www.fotile.com.my

 016-207 8978

Authorized Dealer

260401

WARRANTY :

Range Hood - 3-year warranty for general parts, 10-year warranty for motor*

Gas Hob - 2-year warranty for general parts, 10-year warranty for tempered glass*

Electric Hob, Oven, Microwave Oven, Steam Oven, Combi Oven, Dishwasher - 2-year warranty for general parts*

One Oven Series - 1-year warranty for general parts*

Water Purifier - 2-year warranty for general parts*

* Terms & Conditions apply. Price of hood is inclusive of 1 standard 7" ducting, 1 end cap and 1 flue extension with U-bracket.
All prices, pictures, colours, models, diagrams & specifications are for reference purposes only and are subject to change without prior notice.